



MTS Alignment Solution

Improve accuracy and reliability of test system data

Benefits

- » Helps ensure compliance with numerous industry standards:
 - ASTM E1012
 - GE S-450
 - GE S-400
 - ISO 23788
 - NASM 1312
- » Features precision fixture, flat or round strain-gaged specimens, PC with software, and data acquisition/conditioning unit
- » Intuitive Alignment Wizard guides user through full sequence of concentric and angular adjustments
- » Compact and portable
- » Windows 10 compatible

MTS offers an efficient, easy-to-implement load train alignment solution to help drive test machine variability out of the material testing equation. The turnkey MTS Alignment Solution features a precision Model 609 Alignment Fixture, a selection of strain-gaged specimens, and the necessary software, data acquisition and conditioning functionality required to achieve regular, proper alignment on even a large number of material test systems, protecting the accuracy and reliability of test lab data.

Model 609 Alignment Fixture

Serving as the mechanical foundation of the MTS Alignment Solution, the precision Model 609 fixture is engineered to facilitate quick and highly accurate material testing system alignment adjustments. A key benefit of this fixture's design is that it allows angular and concentric adjustments to be performed while the load train is fully preloaded, eliminating inaccuracies caused by small changes in alignment that can occur during the preloading process. Additionally, because the fixture remains preloaded at all times, previous alignment adjustments are not lost when small refinements in alignment are required. Model 609 Alignment Fixtures are compatible with all MTS servohydraulic load frames, and can be readily adapted to work with servohydraulic load frames from other manufacturers.

Model 709 Alignment Software

Working in concert with the alignment solution's data acquisition/conditioning unit, Model 709 Alignment Software acquires and analyzes data on the bending strain occurring within the strain-gaged specimen. The software's intuitive interface enables users to accurately verify how much bending strain is occurring, and if necessary, the easy-to-use "Alignment Wizard" guides them through the sequence of Model 609 angular and concentric

adjustments needed to achieve test system alignment. Continual scanning of bending strains allows verification and alignment during load cycling. When the alignment procedure is finished, the software can generate an Excel report showing verification of load train alignment resolution for a defined target class. The software can also accept calibrated load signals from the test system controller for generating reports on bending strain at various axial load levels.

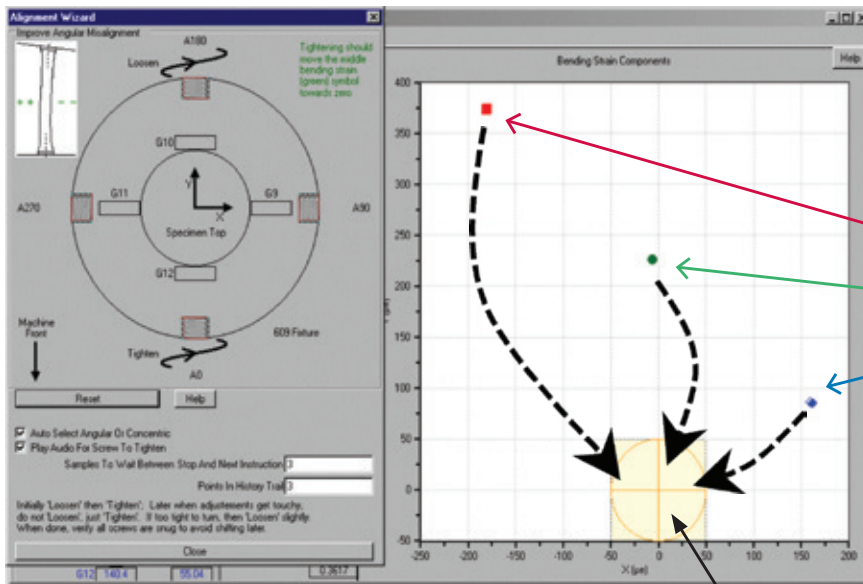

Following software prompts, users adjust concentricity and angularity to bring all bending strains within a 5% bending strain envelope

5% Bending Strain Envelope

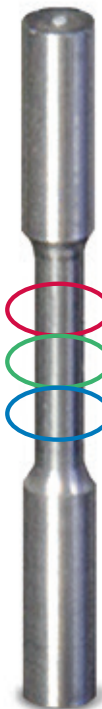

Angularity Adjustment

Concentricity Adjustment



Strain-Gaged Specimens

The MTS Alignment Solution includes a selection of both round and flat standardized, strain-gaged specimens. Each alignment specimen features 12 strain gages, optimal for correcting both concentric and angular test system misalignment. Strain gages are bonded to the alignment specimen with oven-cured epoxy for long life and are covered to prevent damage from handling. Alignment specimens are machined from 4340 steel, and heat treated to safely accommodate stresses up to 413 MPa (60,000 psi). The MTS Alignment Solution can also utilize customer-provided 4, 6, 8, and 9 gage specimens.

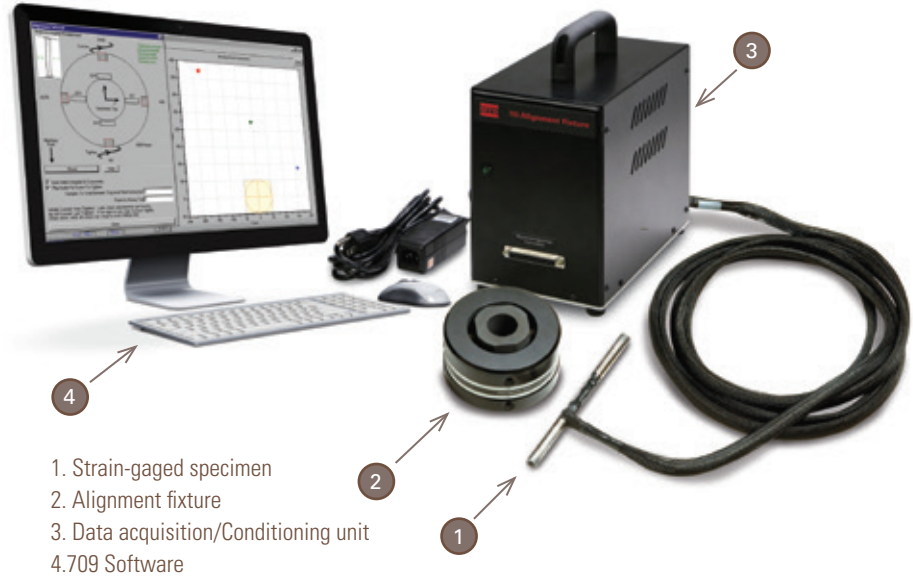

The MTS Alignment Solution is compatible with all MTS servohydraulic load frames, and can be readily adapted to work with servohydraulic load frames from other manufacturers.

MTS Alignment Solution Specifications

Model 609 Alignment Fixtures for Model 312 & 318 Load Frames

Model	Load Frame Force Capacity	Height	Diameter	Stud Size/Length	Metric Part Number	US Customary Part Number
609.02A-01	25 kN (5.5 kip)	72 mm (2.81 in)	121 mm (4.75 in)	M12 x 1.25/355 mm (1/2"-20/14.0 in)	049-083-402	049-083-401
609.10A-01	100 kN (22 kip)	72 mm (2.81 in)	121 mm (4.75 in)	M27 x 2/343 mm (1"-14/13.5 in)	049-083-502	049-083-501
609.25A-01	250 kN (55 kip)	80 mm (3.12 in)	162 mm (6.38 in)	M36 x 2/462 mm (1 1/2"-12/18.2 in)	049-083-602	049-083-601
609.50A-01	500 kN (110 kip)	181 mm (7.11 in)	254 mm (10 in)	M52 x 2/686 mm (2"-12/27 in)	051-499-202	051-499-201

Model 609 Alignment Fixtures for Model 370 Load Frames

Model	Stud Size/Length	Height	Diameter	Capacity	Load Frame Model	Alignment Fixture Mounting Location	Part Number
609.02	M12 X1.25MM X13.5	73mm	124mm	25kN	370.10	Crosshead	057-206-701
609.10	M27 X 2MM X 14.50	73mm	124mm	100kN	370.10	Crosshead	057-206-301
609.10	M27 X 2MM X 16.75	73mm	124mm	100kN	370.25	Crosshead	057-206-307
609.25	M36 X 2MM X 17.25	80mm	162mm	250kN	370.25	Crosshead	057-206-302
609.25	M36 X 2MM X 24.00	80mm	162mm	250kN	370.50	Crosshead	057-206-308
609.50	M52 X 2MM X 25.00	181mm	254mm	500kN	370.50	Crosshead	057-206-303
609.02	M12X1.25MM X11.25	73mm	124mm	25kN	370.02	Base Plate	057-206-201
609.02	M12 X 1.25MM X 16.25	73mm	124mm	25kN	370.10	Base Plate	057-206-702
609.10	M27 X 2MM X 17.00	73mm	124mm	100kN	370.10	Base Plate	057-206-304
609.10	M27 X 2MM X 19.50	73mm	124mm	100kN	370.25	Base Plate	057-206-309
609.25	M36 X 2MM X 20.00	80mm	162mm	250kN	370.25	Base Plate	057-206-305
609.25	M36 X 2MM X 20.00	80mm	162mm	250kN	370.50	Base Plate	057-206-310
609.50	M52 X 2MM X 21.00	181mm	254mm	500kN	370.50	Base Plate	057-206-306

Alignment Software*

Part Number
709.20E-03 Alignment Software

*Requires Windows 10. Supports 709.20E Alignment Data Acquisition and Conditioning Units with MTS Part Numbers 058-570-9XX, 57-675-5XX & 56-776-6XX.

Strain-Gaged Specimens

Part Number
Round (Metric)
Round (US Customary) 1/2"
Round (US Customary) 1"
Flat

Voltage Plug

Part Number	Certified Part Number
115 V AC, US Plug, CE	058-570-901
230 V AC, US Plug, CE	058-570-902
230 V AC, Euro Plug, CE	058-570-903
230 V, UK/Ireland Cordset, CE	058-570-904
230 V AC, Chinese Cordset, CE	058-570-905

709.20E Alignment Data Acquisition and Conditioning Units
For other plug options, contact MTS.

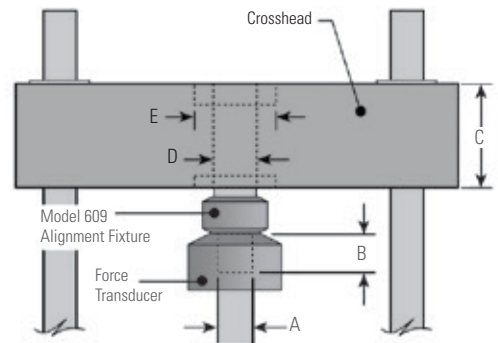
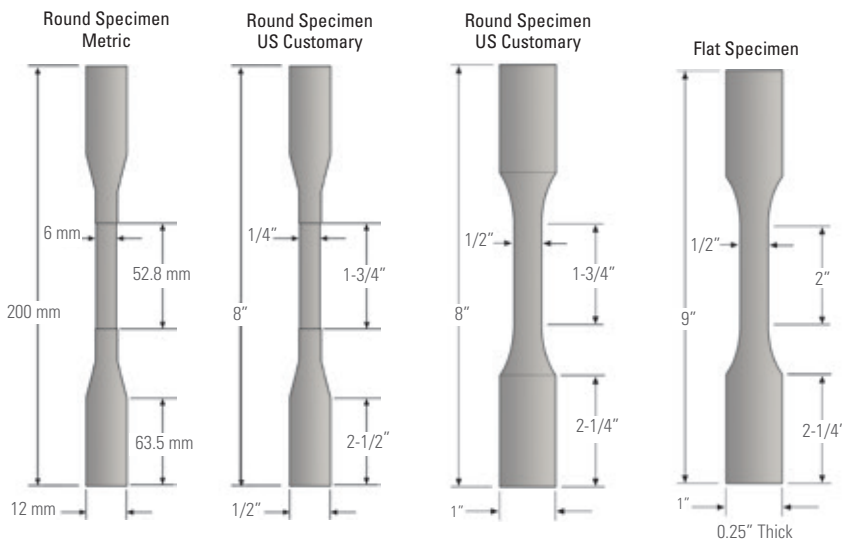

Adapter Kit: required information for ordering Model 609 fixture for load frames other than MTS Models 370, 318, & 312

- A. Force transducer thread size
- B. Force transducer thread depth
- C. Crosshead height
- D. Crosshead through-hole diameter
- E. Dimensional information of any counter-bores in either the top or bottom of the crosshead

Specifications subject to change without notice.

MTS is a registered trademark of MTS Systems Corporation within the United States. This trademark may be protected in other countries. RTM No. 211177.

©2024 MTS Systems Corporation
100-001-531h AlignmentSolution • Printed in U.S.A. • 06/24



MTS Systems Corporation
14000 Technology Drive
Eden Prairie, MN 55344-2290 USA
www.mts.com

Telephone: 1.952.937.4000
Toll Free: 1.800.328.2255
E-mail: info@mts.com
ISO 9001 Certified QMS