



Model 633.11 Elevated Temperature Axial Extensometer

For static and dynamic applications ranging from 40° to 540° C

- » Highly accurate and reliable
- » Meets or exceeds ASTM E83 Class B1 and ISO 9513 Class 0.5 standards
- » Low activation force - 60 grams for contact without slippage
- » Can remain attached through specimen failure without incurring damage
- » Patented Quick-Attach springs enable easy mounting on both flat and round specimens

MTS Model 633.11 extensometers are specially designed for measuring axial strain in elevated temperature testing environments without external cooling. They provide stable output, with low creep, for both tension and fatigue testing applications at temperatures ranging from 40° to 540° C (100° to 1000°F).

U.S. Customary versions of this extensometer feature a gage length of 1.000 inch and a travel range of -0.080 to +0.160 inch. SI Metric units feature a gage length of 25.00 mm and a travel of -2.00 to +4.00 mm. The strain range for all models is -8.0% to +16%.

Like all MTS extensometers, the Model 633.11 features a unique cross-flexure design, which assures true center-point bending. The result is low hysteresis and low activation forces for exceptionally accurate

strain readings, and extended travel capability for measuring post-yield behavior up to specimen fracture. Mechanical stops that make it possible to leave them attached through specimen failure without incurring damage. Additionally, a zero-set pin enables accurate and consistent determination of initial extensometer gage lengths.

Model 633.11 extensometers come standard with hardened, replaceable knife edges for both flat and round specimens. These knife edges feature a symmetrical design that minimizes their susceptibility to chipping and wear. Optional knife edge sets are available for use with a variety of specimen geometries and materials. These units also come standard with Quick-Attach springs (U.S. Patent 4,507,871), which make mounting to flat or round specimens fast and easy.

The standard Model 633.11 kit also features a compact Converter Module that contains the necessary electronics for high level output to the test system controller. This module affixes easily to a test frame load column via straps. The Converter Module comes with its own power supply, which provides the required input power of +/-15 Vdc at 200 mA. 633.11 cabling is strain-relieved and potted directly to the sensing unit to minimize solder connections and assure maximum signal integrity.

Each Model 633.11 extensometer is packed in a rugged storage case that contains the instrument, converter module, spare parts, springs, attachment devices and tools.

Standard Accessories

KNIFE EDGE SETS

- » Two straight sets, one installed, for round specimens.
- » One three-point set for flat specimens

CONVERTER MODULE

- » Includes power supply (± 15 Vdc)

CABLING

- » From Converter Module to Power Supply to MTS controller or conditioner
- » Choice of 7.62 m (25 ft) or 15.24 m (50 ft)

Optional Extensometer Calibrator

- » Model 650.03 for calibrating at room temperature (ambient)
- » Available in US Customary and SI metric versions

Contact your local MTS sales representative to determine the setup most appropriate for your specific test system/application.

Specifications

ACCURACY

Meets or exceeds ASTM E83 Class B1 and ISO 9513 Class 0.5 standards

MAXIMUM STRAIN¹

- » +16 to -8.0%

ACTIVATION FORCE (MAXIMUM)

- » 60 g

NONLINEARITY²

- » Typical: 0.15% of range
- » Maximum: 0.20% of range

HYSTERESIS³

- » 0.15% of range maximum

RELATIVE HUMIDITY⁴

- » 85% maximum

SHIPPING WEIGHT

- » 1 kg (2.2 lb)

QUICK ATTACH SPECIMEN SIZE LIMITS

- » Diameter: 4.5 to 14.5 mm (0.18 to 0.57 in)
- » Flat width: 10.5 to 25.4 mm (0.40 to 1.00 in)
- » Thickness: 0.3 to 19.0 mm (0.01 to 0.75 in)

IMMERSIBILITY

- » These units are not immersible.

CALIBRATION

- » 633.11 extensometers can be calibrated at the MTS factory at temperatures ranging from ambient to customer-specified, or at the customer site by MTS Field Service at ambient temperatures only. Extensometer and associated conditioning electronics can be returned to MTS for repair and recalibration.
- » MTS strongly recommends that calibration be performed at the MTS factory with the extensometer at the expected operating temperature.

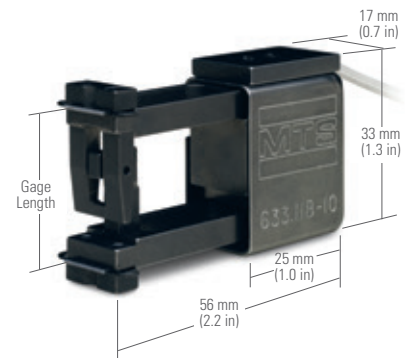

Gage Model	Maximum Length	Temperature Range ⁵	Max Operating Travel	Unit Frequency ⁶	Weight ⁷
633.11L-15	1.000 \pm 0.002 in	185° to 1000°F	-0.080 to +0.160 in	30 Hz	76g
633.11M-15	25.00 \pm 0.05 mm	40° to 540°F	-2.00 to +4.00 mm	30 Hz	76g

¹ Strain is the deflection per unit of gage length (inches/inch or millimeters/millimeter).

² Non linearity specifications calculated using MTS FlexTest® digital controllers.

³ Hysteresis is measured over the \pm maximum travel range and is specified as a percent of this full range.

⁴ Relative humidity in excess of 85% may cause erroneous output. This erroneous output will disappear when chamber temperature is elevated above ambient.

⁵ May be used 50°F (25°C) higher for short durations (less than 24 hours).

⁶ Maximum operating frequency stated for sinusoidal displacements of 0.002 in (0.05 mm) amplitude or less.

⁷ Unit weight includes extensometer and Quick-Attach springs, but does not include cable and connector.



MTS Systems Corporation

14000 Technology Drive
Eden Prairie, MN 55344-2290 USA

Telephone: 1.952.937.4000

Toll Free: 1.800.328.2255

E-mail: info@mts.com

www.mts.com

ISO 9001 Certified QMS

Specifications subject to change without notice.

MTS and FlexTest are registered trademarks of MTS Systems Corporation within the United States. These trademarks may be protected in other countries. RTM No. 211177.

©2023 MTS Systems Corporation

100-255-063b 633.11 Axial Extensometer • Printed in U.S.A. • 12/23