

## Model 814 Spinning Torsion System

Accurately evaluate automotive clutch dampers, assemblies and accessories

### Capabilities

- » Accurately simulates engine torsional vibration
- » Supports evaluation of clutch dampers, assemblies and accessories for both automatic and manual transmissions
- » Covers a broad range of torque and speed requirements to meet evolving industry demands
- » Available in compact bench or easy-access platform styles
- » Employs versatile FlexTest controls & industry-leading MTS application software

The MTS Model 814 Spinning Torsion System is engineered to simulate automotive engine loads for the purpose of analyzing, evaluating and validating damping and vibration in clutch systems. Designed to accommodate both manual and automatic transmissions, the system can be configured for testing clutch dampers, entire clutch assemblies and front-end accessory drive components.

The Model 814 employs an electric drive motor to simulate an automotive engine running at operating speed, while an advanced spinning torsional actuator applies real-world engine vibrations to clutch systems and components. The spinning actuator can superimpose a

dynamic torsional signal of either torque or angular motion onto specimens. FlexTest digital controls and MTS transducers combine to provide precision control and monitoring of angular displacement, acceleration and torque. Proven MTS application software is used to perform a full complement of activities, ranging from simple block cycle testing to more advanced simulations of real-world clutch operating environments

Model 814 systems are available in compact bench or easy-to-access platform styles. They can be operated with a variety of electronic controllers, depending on the complexity of your testing needs, and several types of test setups are possible.

## Test Applications

### » Clutch Damper Testing

For characterization and durability testing of clutch dampers, the Model 814 operates in the self-reacted mode. Torque from the torsional actuator is transmitted to the specimen and then reacted back to the actuator housing. This is achieved by two concentric shafts extending from the actuator: an inner shaft which is the actuator's rotor shaft, and an outer, hollow shaft which is an extension of the actuator housing.

### » Clutch Assembly Testing

To test full clutch assemblies, the Model 814 is set up to run in the inertial reacted mode. In this configuration, the torque generated by the actuator is reacted by the inertial mass of the actuator housing. In this way, it inputs torsional vibration to the entire clutch assembly. This setup can also be used for testing transmissions for gear rattle.

### » Accessory Assembly Testing

To test engine accessories as they are subjected to torsional vibration, the Model 814 is set up to run in the inertially reacted mode. In this configuration, the torque generated by the actuator is reacted by the inertial mass of the actuator housing. The actuator applies torsional vibration to the entire accessory assembly or component. This setup can also be used for testing transmissions for gear rattle or engine Noise, Vibration & Harshness (NVH).

## Available System Configurations

Model 814 systems are available in compact bench or easy-to-access platform styles:

### Bench-style

Bench-style Model 814 systems feature a compact footprint with a built-in drip tray and motor mounted beneath table.

With Specimen Guard



With Temperature Chamber



### Platform-style

Low-to-the-floor Platform-style Model 814 systems allow for easier specimen installation and access to motors and belts. No drip tray is included.

With Specimen Guard

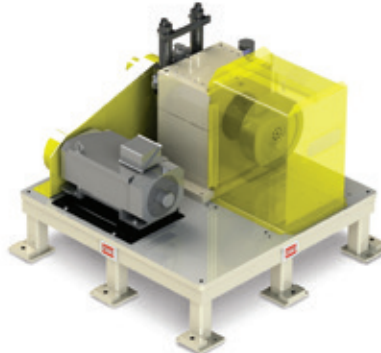

With Temperature Chamber

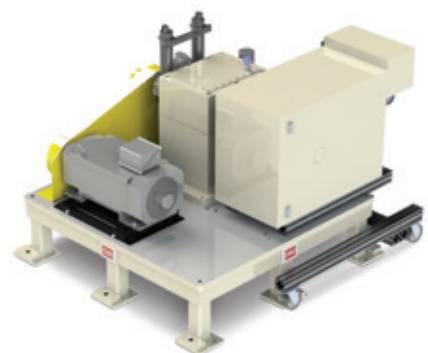

## Functional Diagram

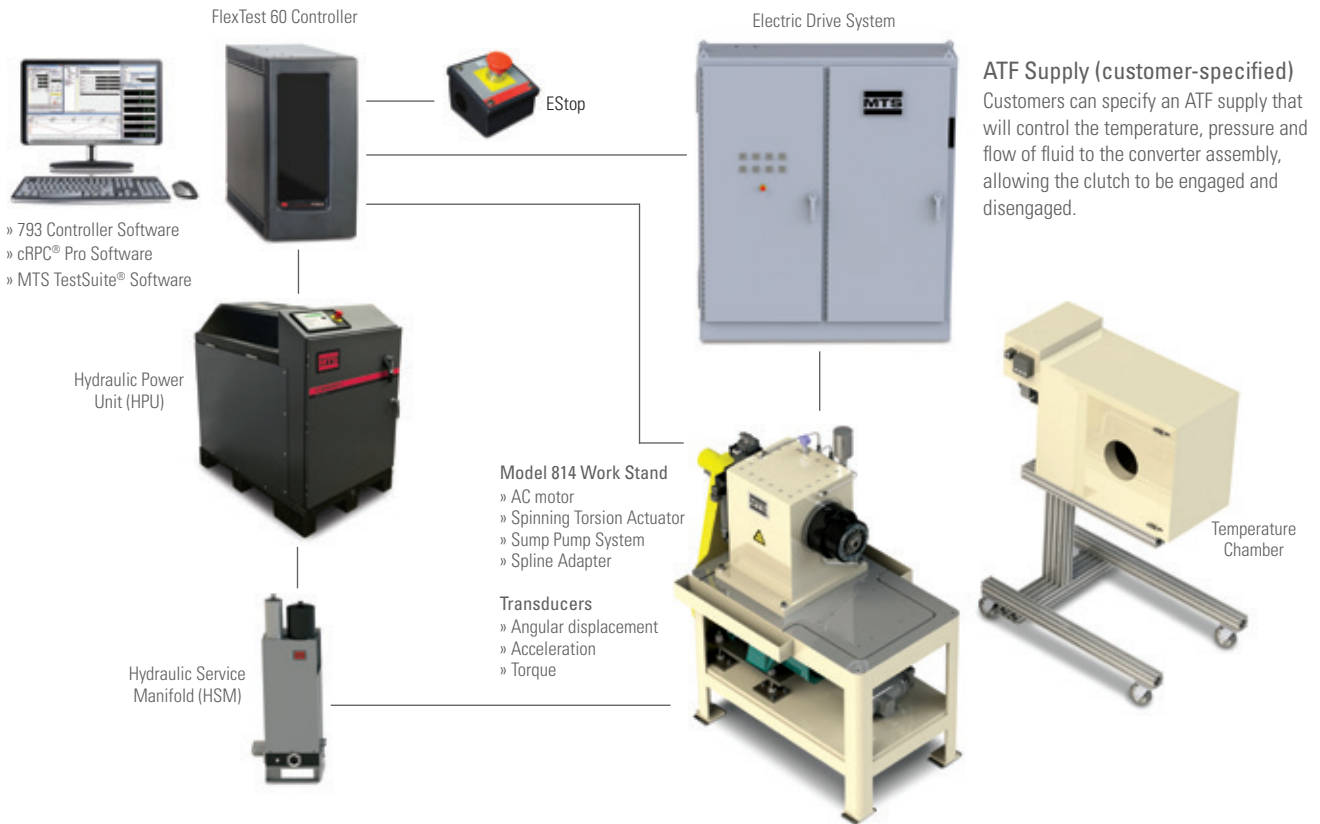

## Versatile MTS Controls & Easy-to-use Application Software

Model 814 systems feature modular FlexTest digital controllers, which are renowned for their scalability, advanced tuning and compensation tools and intuitive 793 software user interface.

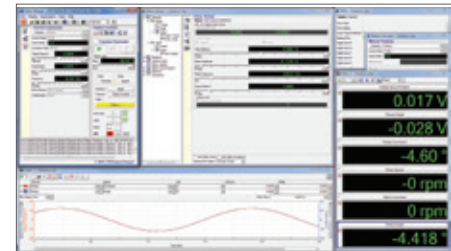

FlexTest Controller & 793 Software

MTS TestSuite® Software provides new tools for creating and running tests, generating reports and analyzing test data for material and component tests. It provides unparalleled control over testing operations: calculations are transparent and modifiable and test design is performed through an innovative workflow interface that allows designers to visualize the tests they are creating in intuitive flow chart format.

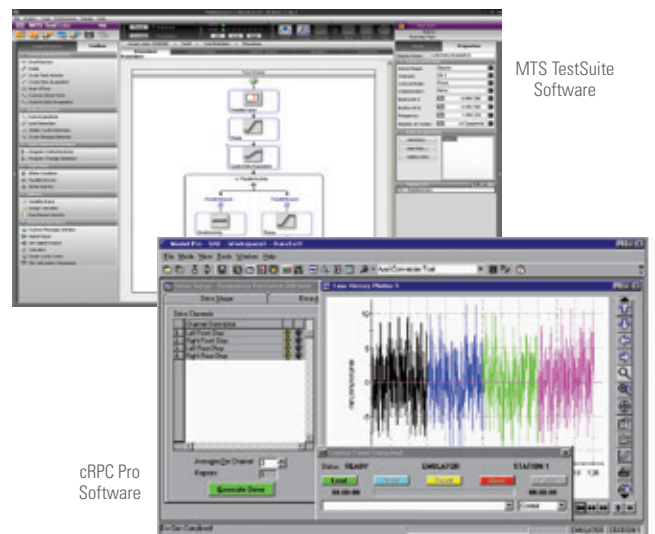

Industry-leading **Component RPC® Pro (cRPC) software** minimizes testing time through advanced editing, analysis and simulation capabilities. cRPC Pro software can complement existing test systems or provide a powerful application for new test simulation that can be customized and automated to meet your specific needs.

## Model 814 Performance Specifications\*

Torque [Nm]	Dynamic Angular Displacement [ +/- deg]	Static Angular Displacement [ +/- deg]	Speed [rpm]
1500	135	140	7000
1500	135	140	7000
3000	65	70	7000
4500	45	50	4000

\*Specifications subject to change

### Facility Requirements

The Model 814 design allows for flexibility in its application, therefore final system dimensions will vary depending on style (bench or platform) and intended system use:

- » System bed plates can rest on rubber isolation pads on a concrete floor, or be anchored with grouting to a concrete floor; a seismic mass is not required.
- » The required hydraulic power supply should provide 75 gpm at 3000 psi.
- » Optional automatic transmission fluid requirements are determined during technical discussions

### Global MTS Service & Support

Test professionals throughout the world rely on MTS' innovative technologies, high-quality test systems and applications expertise to optimize their testing programs. We complement this industry-leading portfolio with an unmatched suite of global service and support, all designed to increase your uptime and reduce your total cost of ownership.

By supporting your test program from facilities planning and system integration through final equipment de-commission, MTS offers a single, reliable resource for helping you optimize your system performance, manage your budget, protect your data integrity and maintain your schedule predictability.



#### MTS Systems Corporation

14000 Technology Drive  
Eden Prairie, MN 55344-2290 USA

Telephone: 1.952.937.4000

Toll Free: 1.800.328.2255

E-mail: [info@mts.com](mailto:info@mts.com)

[www.mts.com](http://www.mts.com)

ISO 9001 Certified QMS

MTS, FlexTest, MTS TestSuite and RPC are registered trademarks and SilentFlo is a trademark of MTS Systems Corporation in the United States. These marks may be protected in other countries. RTM no. 211177.

Products or company names other than trademarks of MTS Systems are used for identification purposes only and may be trademarks of their respective owners.

©2024 MTS Systems Corporation

100-348-872b SpinningTorsion814 • Printed in U.S.A. • 01/24